

OPERATION AND MAINTENANCE INSTRUCTIONS

CONTROLLING THE FAN SPRAY:

The fan spray for an external mix nozzle set-up is easily controlled by means of the Side Port Control 54-3347. Turning this control to the right, or clockwise, until it is closed will give a round spray; turning it to the left, or counterclockwise, will widen the spray into a fan shape of any width desired. The direction of the fan spray, either horizontal or vertical, is obtained by turning the air nozzle to the desired position, then tightening the retainer ring.

CONTROLLING THE FLUID: If a fluid pressure tank is used, the amount of fluid can be controlled by regulating the pressure on the tank. The amount of fluid can also be controlled by means of the Fluid Control 54-1007. Turning this screw to the right, or clockwise, reduces the amount of fluid; to the left, or counterclockwise, increases the amount of fluid.

FAULTY SPRAY: A faulty spray is caused by improper cleaning or dried material around the fluid nozzle tip or in the air nozzle. Soak these parts in a solvent that will soften the dried material and remove with a brush or cloth. Never use metal instruments to clean the air or fluid nozzles. These parts are carefully machined and any damage to them will cause a faulty spray. If either the air nozzle or fluid nozzle is damaged, the part must be replaced before a perfect spray can be obtained.

TO REPLACE THE FLUID PACKING: Remove the Fluid Control Screw 54-1007, Spring 54-1347 and needle. Then remove the Fluid Packing Nut 56-164 and take out the old packing with a small stiff wire. Replace with new Packing 2-28. To set packing, insert needle, tighten nut until the needle begins to be too stiff for the spring to move needle. Then loosen nut 1/2 to 3/4 turn.

CORRECTING AIR LEAK

THROUGH GUN: Air leaking through the gun is caused by the Valve Stem Assembly 54-1025, not seating properly against the Valve Body 54-1010. Remove the Valve Body 54-1010 and Valve Stem Assembly 54-1025. Thoroughly clean parts and inspect for damage. Replace worn or damaged parts and assemble in reverse order.

CORRECTING AIR LEAK AROUND AIR VALVE STEM: Air leaking around the Air Valve Stem 54-1025 may be caused by worn Packings 8-158 or damaged Air Valve Stem 54-1025. Remove Trigger 54-1050, Packing Nut 82-135 and Packings 82-158. Clean extended portion of Air Valve Stem 54-1025 and inspect for damage; if stem is damaged, replace same as above, insert new packings and assemble in reverse order.

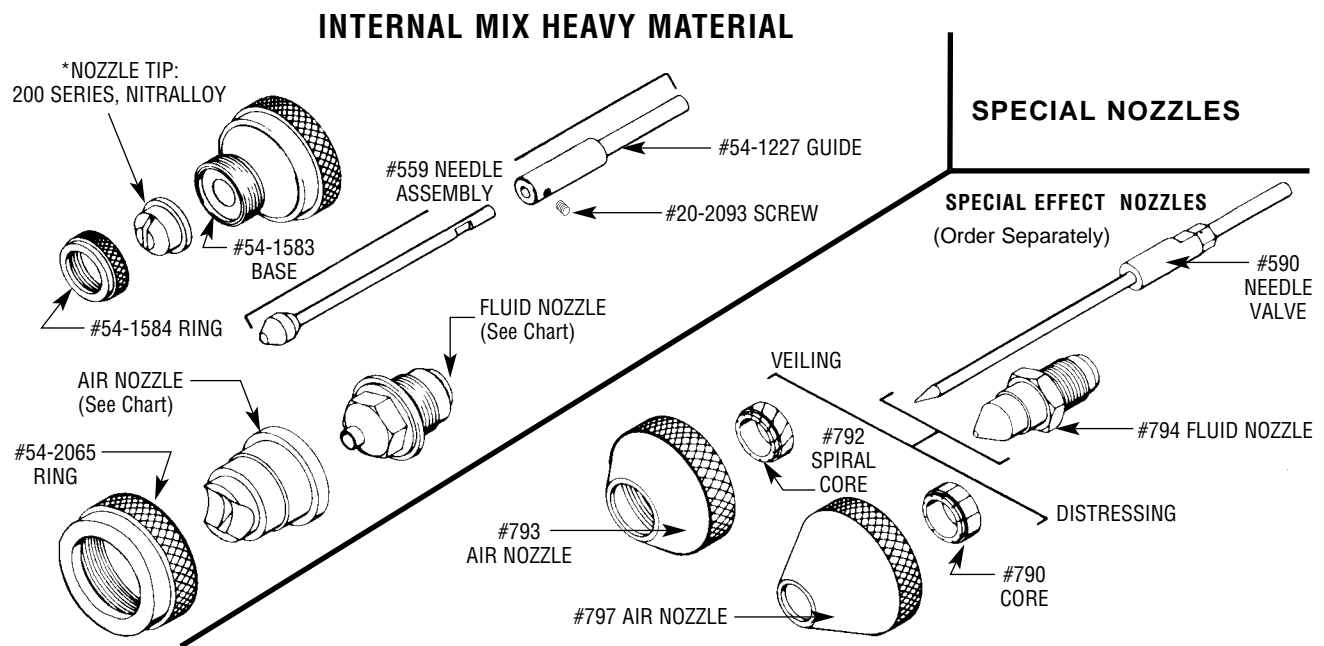

WARRANTY This product is covered by Binks' 1 Year Limited Warranty.

Binks Worldwide Sales and Service Listing: www.binks.com

ITW Industrial Finishing

Binks has authorized distributors throughout the world. For technical assistance or the distributor nearest you, see listing below.

U.S./Canada Technical Service Office:

195 Internationale Blvd., Glendale Heights, IL 60139
Toll-Free Telephone: 1-888-992-4657 (U.S.A. and Canada only)
Toll-Free Fax: 1-888-246-5732

ITW Automotive Refinishing

Binks has authorized distributors throughout the world. For equipment, parts and service, check the Yellow Pages under "Automotive Body Shop Equipment and Supplies." For technical assistance, see listing below.

U.S./Canada Customer Service Office:

1724 Indian Wood Circle, Suite J-K, Maumee, OH 43537
Toll-Free Telephone: 1-800-445-3988 (U.S.A. and Canada only)
Toll-Free Fax: 1-800-445-6643

CLEANING THE GUN—WHEN USED WITH PRESSURE TANK:

Shut off the air supply to the Pressure Tank and release the pressure in the tank. Hold a piece of cloth over the gun nozzle and pull the trigger, the air will back up through the fluid nozzle and force the fluid out of the hose and into the tank. Remove paint from tank, clean tank and put enough compatible solvent into the tank to clean the hose and gun thoroughly. Spray this through the gun until it is clean, then blow out the fluid hose to dry it and remove all traces of materials by attaching it to the air line.

WHEN USED WITH A CUP:

A compatible solvent should be siphoned through gun by inserting tube from siphon cup in an open container of solvent. Trigger gun intermittently to thoroughly flush passageways and internal parts.

HOW TO USE THE CHART

A. MATERIAL TO BE SPRAYED

Select the type of fluid you want to spray or a fluid which has the same characteristics as one of those listed.

B. METHOD OF FEEDING MATERIAL TO THE GUN

Fluid Nozzle—Consider the speed of application and the viscosity of the fluid to be sprayed. Refer to the Fluid Nozzle Orifice Size Chart, below.

Air Nozzle—Choice is determined by the type of fluid to be sprayed and the volume of air available for the gun.

- External Mix Nozzles, which are generally used, accomplish atomization outside the nozzle. Spray patterns are adjustable from round to fan with all intermediate patterns. (Designated by the letter “E”).
- Siphon Type External Mix Nozzles, designated by the letter “S”, will siphon the material from a cup. Used generally for refinished and touch-up work which does not require large quantities of paint.
- Pressure Type External Mix Nozzles, designated by the letter “P”, require pressure to feed the material to the nozzle. A pressure cup, pressure tank or pump is necessary. Used for production work and where large

quantities of fluid are handled. This type of nozzle has a greater range of fluid flow and does not limit the size of the paint container.

- Internal Mix Nozzles mix the air and fluid within the air nozzle. The spray pattern is determined by the shape of the nozzle and cannot be changed. Internal mix nozzles require less air and produce slightly less fog. Pressure equipment must be used with this type of nozzle. Recommended for maintenance spraying of heavy materials where a fine finish is not required. (Designated by the letter “T”).

C. VOLUME OF AIR (CFM REQUIRED)

The cubic feet per minute (CFM) listed at 30, 50 and 70 PSI is the actual air used by the air nozzle. Increase of pressure subsequently increases volume of air required by air nozzle, or vice versa. Assume that a compressor will produce 3-5 CFM per horsepower.

NOTE

The greater the air consumption, the faster the fluid may be applied or the finer a given amount of fluid can be atomized.

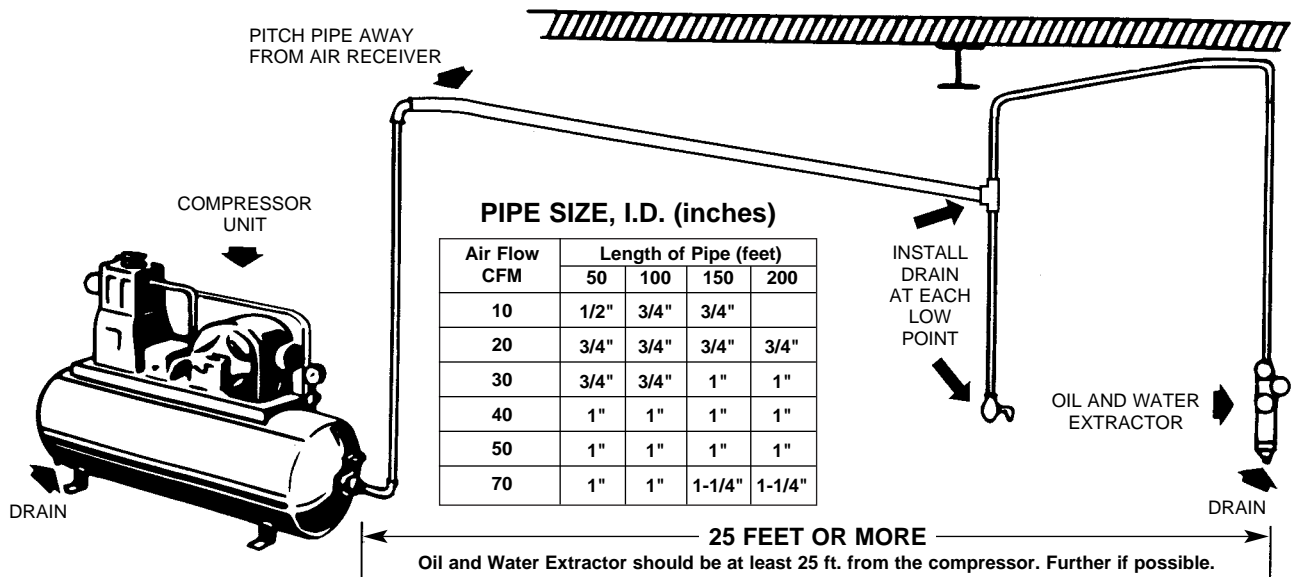

It is extremely poor practice to mount the oil and water extractor on or even near the compressor unit. The temperature of the air is greatly increased as it passes through the compressor and this compressed air must be cooled before the moisture in it will condense. If the air from the compressor is still warm when

it passes through the oil and water extractor, moisture will not be effectively removed, but will remain in suspension. Then, when the air cools in the hose beyond the extractor, the moisture will condense into drops of water and cause trouble.

Air lines must be properly drained.

Pitch all air lines back towards the compressor so that condensed moisture will flow back into the air receiver where it can be removed by opening a drain. Every low point on an air line acts as a water trap. Such points should be fitted with an easily accessible drain. See diagram above.

TYPE OF FLUID TO BE SPRAYED	FLUID NOZZLE	AIR NOZZLE	TYPE *	CFM AT			MAX. PAT. (inches) AT 8 in.	FLUID Needle No.★
				30 PSI	50 PSI	70 PSI		
VERY THIN								
14–16 SECS.—NO. 2 ZAHN	63BSS	63P	PE	4.5	7.5	10.0	5.0	563
WASH PRIMERS	63BSS	63PB	PE	9.0	14.3	20.0	14.0	563A
DYES, STAINS	66SS	66SD	SE	7.9	12.1		10.5	565
SOLVENTS, WATER, INKS	66SS	66SK	SE	11.0	15.2	19.5	13.0	565
THIN								
16–20 SECS.—NO. 2 ZAHN	63BSS	63PB	SE	9.0	14.3	20.0	14.0	563A
SEALERS, PRIMERS	66SS	66S	SE	7.0	12.0			565
LACQUERS	66SS	66SK	SE	11.0	15.2	19.5	13.0	565
ACRYLICS								
MEDIUM								
19–30 SECS.—NO. 2 ZAHN	63BSS	63PB	PE	9.0	14.3	20.0	14.0	563A
LACQUERS, SYN. ENAMELS	66SS	66SD	SE	7.9	12.0		11.0	565
VARNISHES, SHELLACS	66SS	66SK	SE	11.0	15.2	19.5	13.0	565
FILLERS, PRIMERS								
URETHANES, LUBRICANTS								
HEAVY (CREAM-LIKE)								
OVER 28 SECS.—NO. 4 FORD	67SS	67PB	PE	9.5	14.1	19.1	12.0	567
HOUSE PAINT	68SS	68PB	PE	9.5	14.1	19.1	12.0	568
WALL PAINT (OIL, LATEX)	67SS	201	PI	4.6	6.8	9.1	11.0	568
BLOCK SEALERS, MILL WHITES								
VINYLS, ACRYLICS, EPOXIES								
VERY HEAVY								
UNAGGREGATED	68SS	68PB	PE	9.5	14.1	19.1	12.0	568
BLOCK FILLERS	59ASS	244	PI	7.8	11.5	15.2	12.0	559
TEXTURED COATINGS								
FIRE RETARDANTS								
ROAD MARKING PAINT								
BITUMASTICS								
CELLULAR PLASTISOLS								
UNDERBODY								
ROOF COATINGS								
ADHESIVES								
WATERBASE	66SS	66SD-3	PE	7.9	12.1	16.2	15.0	565
WHITE VINYL GLUE	67SS	67PB	PE	9.5	14.1	19.1	12.0	567
SOLVENT BASE	63	66SD	PE	7.9	12.1	16.2	15.0	563
NEOPRENES								
(CONTACT CEMENTS)								
MULTICOLOR PAINTS								
	66SS	200	PI	3.1	5.2		12.0	565
TEFLONS								
	63BSS	63PB	PE	9.0	14.3	20.0	10.0	563A
	66SS	66SD	SE	7.9	12.1		7.0	565
HAMMERS								
	66SS	66SD	SE	7.9	12.1		7.0	565
SPECIAL EFFECT FINISHES								
	SOLD ONLY AS ACCESSORIES, ORDER SEPARATELY.							
VEILING	794	793	PE	3 AT 15 PSI				590
DISTRESS FINISH	794	797	PE	3 AT 15 PSI				590
SPATTER FINISH	66	66PD	PE	3 AT 15 PSI				565
FLUID NOZZLE ORIFICE SIZES								
59ASS	63BSS	66SS	67SS	68	794			
.171	.046	.070	.086	.110	.040			

*See text Section B, page 2, for type code. ★All needles listed are hardened stainless steel.

Binks MODEL 2001SS SPRAY GUN

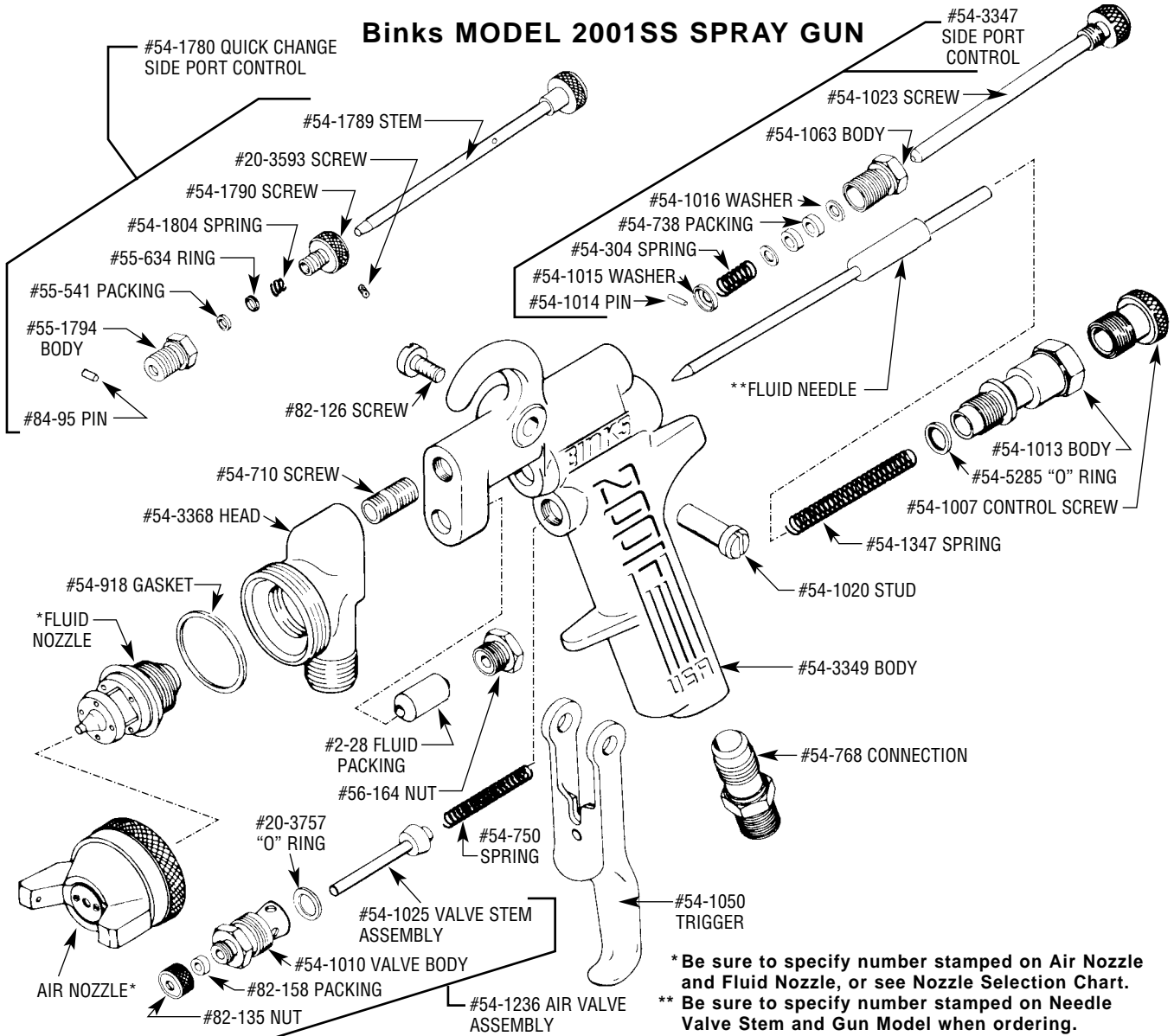

* Be sure to specify number stamped on Air Nozzle and Fluid Nozzle, or see Nozzle Selection Chart.
 ** Be sure to specify number stamped on Needle Valve Stem and Gun Model when ordering.

PARTS LIST

PART NO.	DESCRIPTION	QTY.	PART NO.	DESCRIPTION	QTY.
See Note * Above	AIR NOZZLE	1	54-1016	WASHER.....	2
See Note * Above	FLUID NOZZLE.....	1	• 54-1020	STUD.....	1
See Note ** Above	FLUID NEEDLE.....	1	54-1023	SCREW	1
• 20-3757	"O" RING	1	• 54-1025	VALVE STEM ASSEMBLY	1
○ • 20-5285-5	"O" RING	1	54-1050	TRIGGER	1
○ • 54-304-5	SPRING.....	1	54-1063	BODY	1
54-710	SCREW.....	1	54-1236	AIR VALVE ASSEMBLY	1
○ • 54-738-5	PACKING	2	○ • 54-1347-5	SPRING.....	1
○ • 54-750-5	SPRING.....	1	* 54-1780	QUICK CHANGE SIDE PORT CONTROL (Optional).....	1
▲ • 2-28-10	FLUID PACKING.....	1	54-3347	SIDE PORT CONTROL	1
54-768	CONNECTION	1	54-3368	HEAD.....	1
○ • 54-918-5	GASKET	1	54-3349	BODY (NOT FOR SALE)	1
54-1007	CONTROL SCREW	1	56-164	NUT	1
54-1010	VALVE BODY	1	○ • 82-126-5	SCREW	1
54-1013	BODY	1	○ 82-135-5	NUT	1
○ • 54-1014-5	PIN.....	1	○ • 82-158-5	PACKING	1
54-1015	WASHER.....	1			

○ Available only as 5-pack
 • Indicates parts in Repair Kit 6-229
 ▲ Available only as 10-pack

* Accessory Item
 Accessories: 56-126 Plug may replace the 54-3347 Assembly when using internal mix nozzles.